

CAME UNITED KINGDOM LTD
UNIT 3,
ORCHARD PARK INDUSTRIAL ESTATE,
TOWN STREET, SANDIACRE,
NOTTINGHAM NG10 5BP

TEL: 0115 921 0430
FAX: 0115 921 0431

INTERNET - www.cameuk.com
E-MAIL - enquiries@cameuk.com



TECHNICAL
HELPLINE
0115 921 0430

FAST KIT

Installation Instructions



FAST-P, Pair of gates automation kit

Kit consists of :

- 2 x fast motors 240V
- 1 x built-in control panel 240V
- 1 x radio receiver
- 1 x tuned antenna
- 2 x remote control handsets
- 1 x pair safety photocells
- 1 x flashing "in movement" light
- Full installation guide

FAST-S, Single gate automation kit

Kit consists of :

- 1 x fast motor 240V
- 1 x built-in control panel 240V
- 1 x radio receiver
- 1 x tuned antenna
- 2 x remote control handsets
- 1 x pair safety photocells
- 1 x flashing "in movement" light
- Full installation guide

INTRODUCTION

These instructions will show you how to install a FAST gate kit to a pair of gates.

Please read these instructions and diagrams carefully before starting any work.

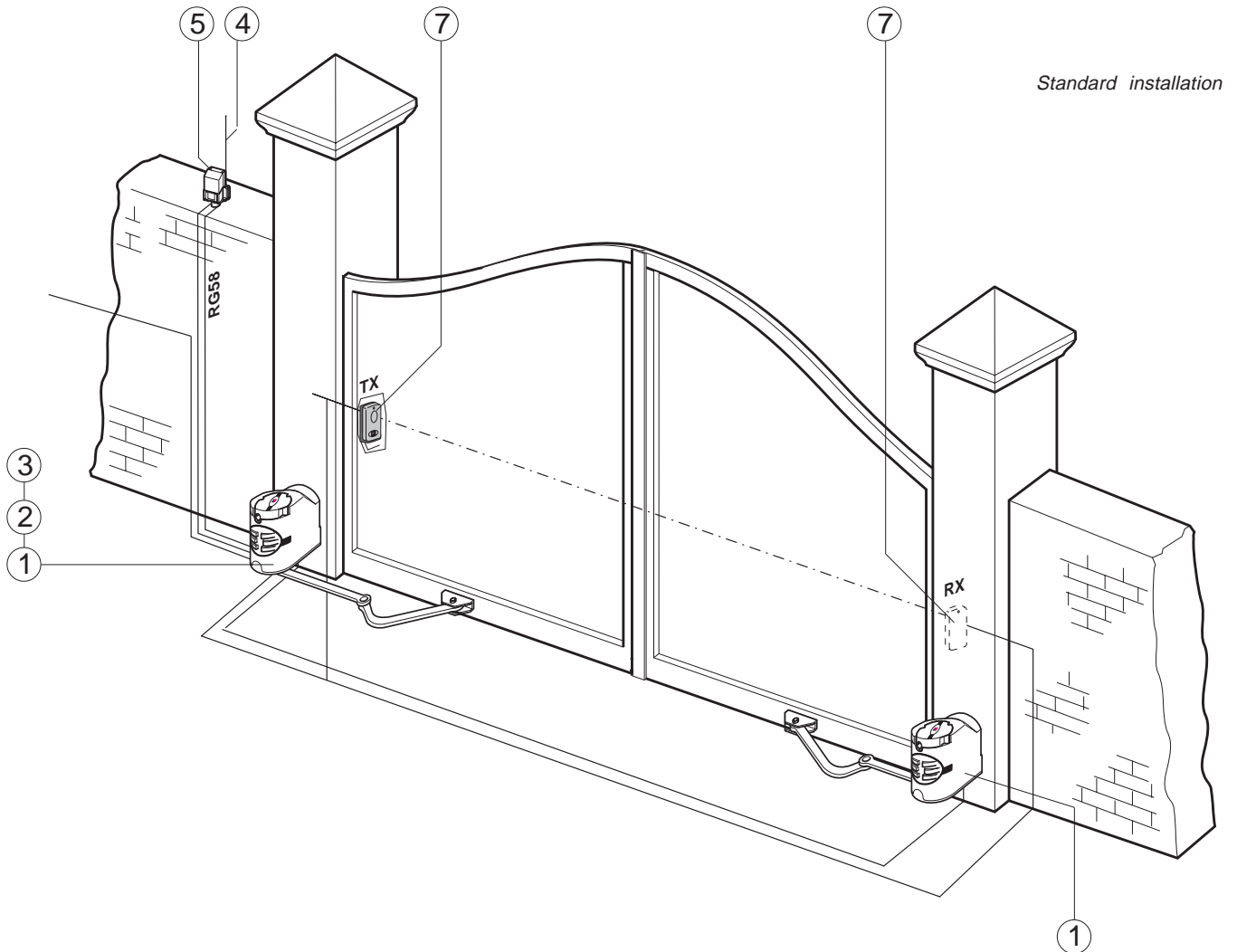

Installation Type

1 - Gear Motor

Accessories:

2 - Control panel

3 - Radio receiver

4 - Antenna

5 - Flashing light indicating door movement

7 - Safety photocells

UNDER NO CIRCUMSTANCES SHOULD THIS EQUIPMENT BE OPERATED UNLESS FITTED TO A GATE.

FAILURE TO COMPLY WILL INVALIDATE THE GUARANTEE.

INSTALLATION INSTRUCTIONS

CONTENTS

1) Stage 1:- Civil & Mechanical Section	Page
1.1 PRE-INSTALLATION CHECK	3
1.2 MOUNTING THE MOTOR BASE PLATE	4
2) Stage 2:- Wiring & Electrical	
2.1 BASIC CABLE LAYOUT	6
3) Stage 3:- Installation Section	
3.1 INSTALLING THE MOTORS	8
3.2 INSTALLING THE DRIVE ARMS	9
3.3 ADJUSTING THE OPEN & CLOSED CAMS	10
4) Stage 4:- Wiring the Motors	
4.1 ELECTRICAL CONNECTIONS TO THE ZF1 BOARD WITH PAIR OF GATES	12
4.2 ELECTRICAL CONNECTIONS TO THE ZF1 BOARD WITH SINGLE GATE	13
4.3 ELECTRICAL CONNECTIONS	14
5) Stage 5:- Commissioning the control Panel	
5.1 INITIAL WIRING & CONTROL PANEL SETUP	16
5.2 OPENING & CLOSING THE GATES	17
5.3 CONTROL PANEL ADJUSTMENTS	18
5.4 AUTOMATIC CLOSE & SAFETY PHOTOCELLS	19
5.5 PROGRAMMING THE REMOTE CONTROLS TO THE CONTROL PANEL	20
5.6 CODING THE ADDITIONAL REMOTE	21
5.7 FINAL ASSEMBLY	22
6) Technical Information	
7.1 ELECTRICAL CONNECTIONS	24
7.2 FUNCTION SELECTIONS	25
7.3 TECHNICAL DESCRIPTION - ZF1 CONTROL PANEL	25
7.4 MOTHERBOARD	26
7.5 ADJUSTMENTS	26
7) Troubleshooting Guide	27
8) Contact Information	

“Time marches on but Came automation equipment stands the test of time...”

1.1 - Requirements

EXTERNAL DIMENSIONS AND OPERATING LIMITS

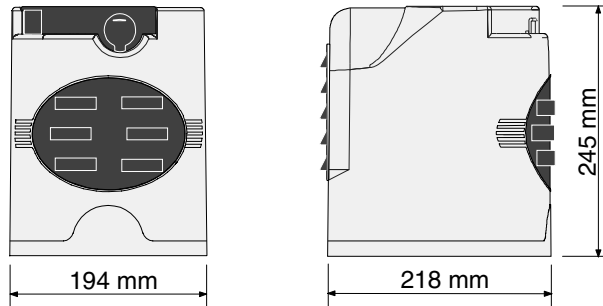

Width of gate wing	Weight of gate wing
1 m	300 Kg
1,5 m	250 Kg
2 m	215 Kg
2,3 m	200 Kg

BEFORE INSTALLING...

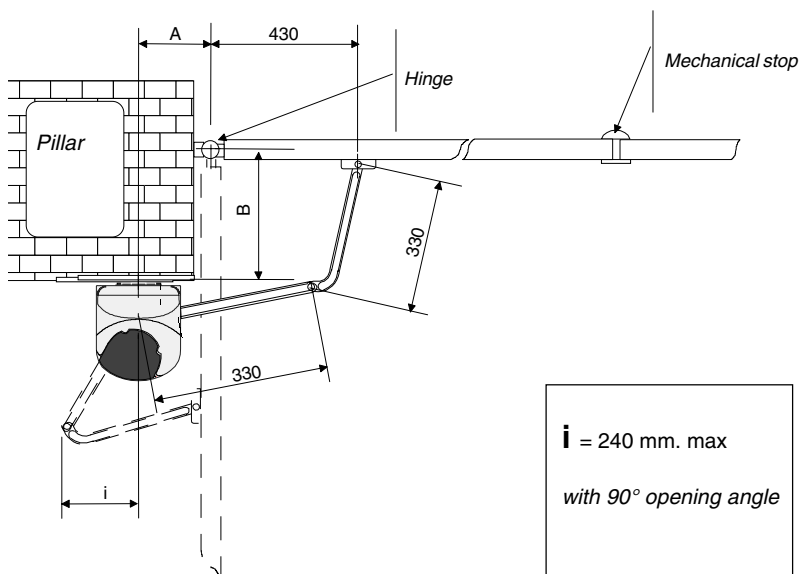

Opening angle	A	B
90°	137-210	0
90°	137-205	50
90°	137-200	75
90°	137-195	100
90°	137-190	125
90°	137-185	150
90°	137-180	175
90°	137-175	200
110°	180-210	0
110°	200-205	50

Before proceeding with the installation of the automation, check the following:

- the structure of the door must be sufficiently sturdy, the hinges must be efficient and there must be no friction between fixed or mobile parts;
- the path of the electrical cables must be made according to the control and safety requirements (see the system type);
- there must be a centre stop firmly secured in the ground for the gates to close onto to prevent the gate overextending,

1.2 - Mounting the Motor Base Plate

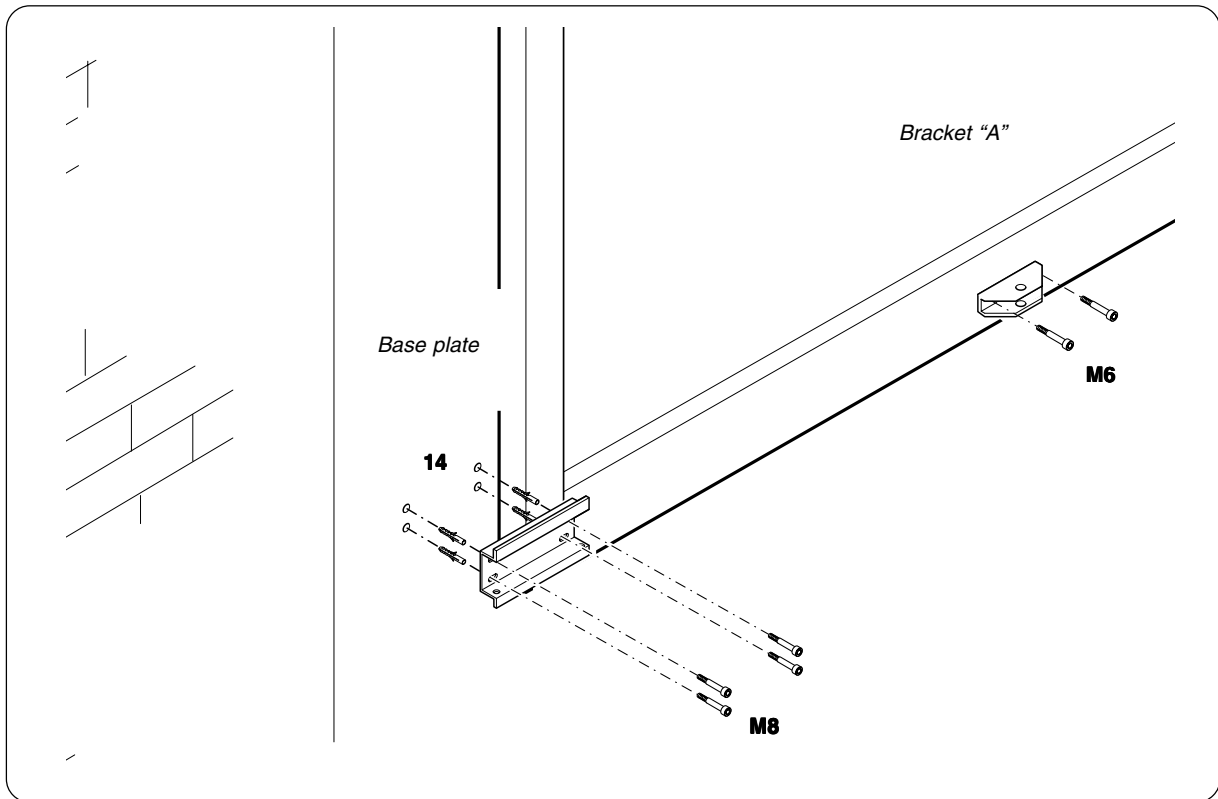

Using suitable anchor bolts or chemical resin for brick pier securely mount the motor plate to the brick pier. For wooden posts it is advised to fix the motor plate to the post. A threaded bar should be placed all the way through the post then bolted.

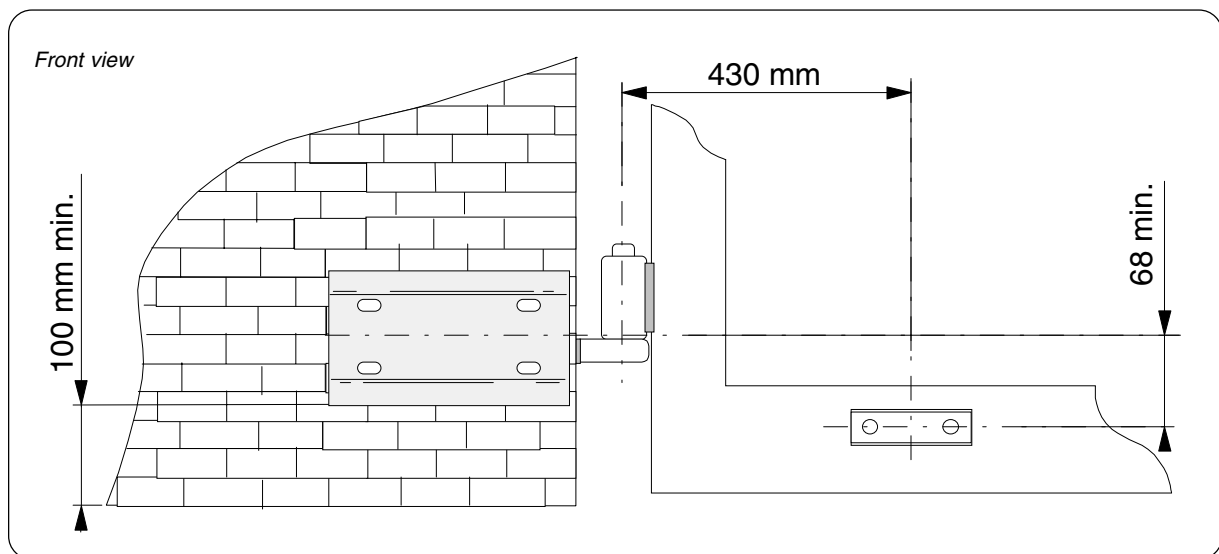
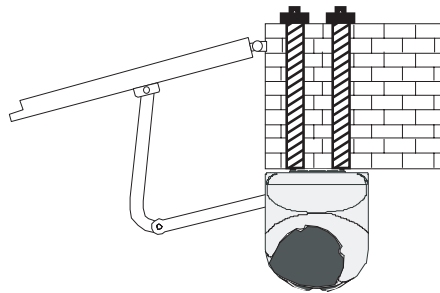

Use M8 screws and $\varnothing 14$ screw anchors to mount the base plate on the pillar. Be sure to respect the 100mm minimum distance from the pavement. Attach bracket "A" to the gate wing (use M6 screws or welds). Be sure to respect the offsets of 430mm and 68mm.

END OF INSTALLATION STAGE 1

**BEFORE STARTING STAGE 2 - Wiring and Electrical
PLEASE CHECK THAT YOU HAVE CORRECTLY:**

	Ref	Page
1. Checked Requirements	1.1	3
2. Mounted Motor Base Plate	1.2	4

**NOW STAGE 1 IS FULLY COMPLETED YOU ARE READY TO BEGIN
STAGE 2 OF YOUR FAST AUTOMATION KIT INSTALLATION.**

STAGE 2 WIRING AND ELECTRICAL

2.1 - Basic Cable Layout

The power supply to the control panel should be live and protected in accordance with the 16th edition electrical regulations. The supply should be rated at a minimum of 6 amps.

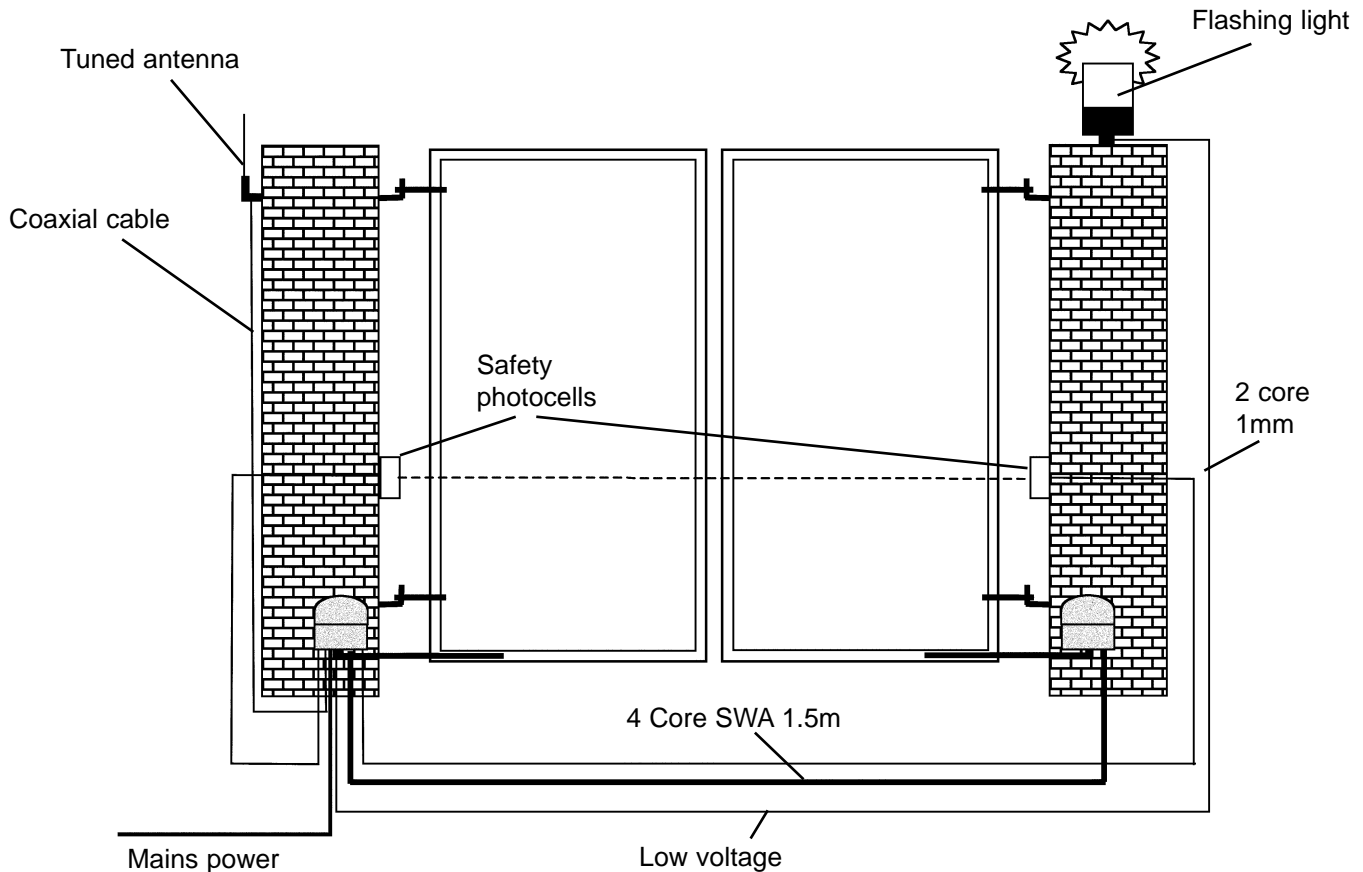

When installing low voltage cable around the gateway it is advised to put all low voltage cable in either ducting or alkanthene piping. All cable jointing should be carried out above ground.

All Came accessories can be wired 0.2m stranded cable (burglar alarm type). The tuned antenna should be wired with coaxial cable (RG59).

END OF INSTALLATION STAGE 2

**BEFORE STARTING STAGE 3 - Installation
PLEASE CHECK THAT YOU HAVE CORRECTLY:**

	Ref	Page
1. Installed Basic Cable Layout	2.1	6

**NOW STAGE 2 IS FULLY COMPLETED YOU ARE READY TO BEGIN
STAGE 3 OF YOUR FAST AUTOMATION KIT INSTALLATION.**

STAGE 3 INSTALLATION

3.1 - Installing the Motors

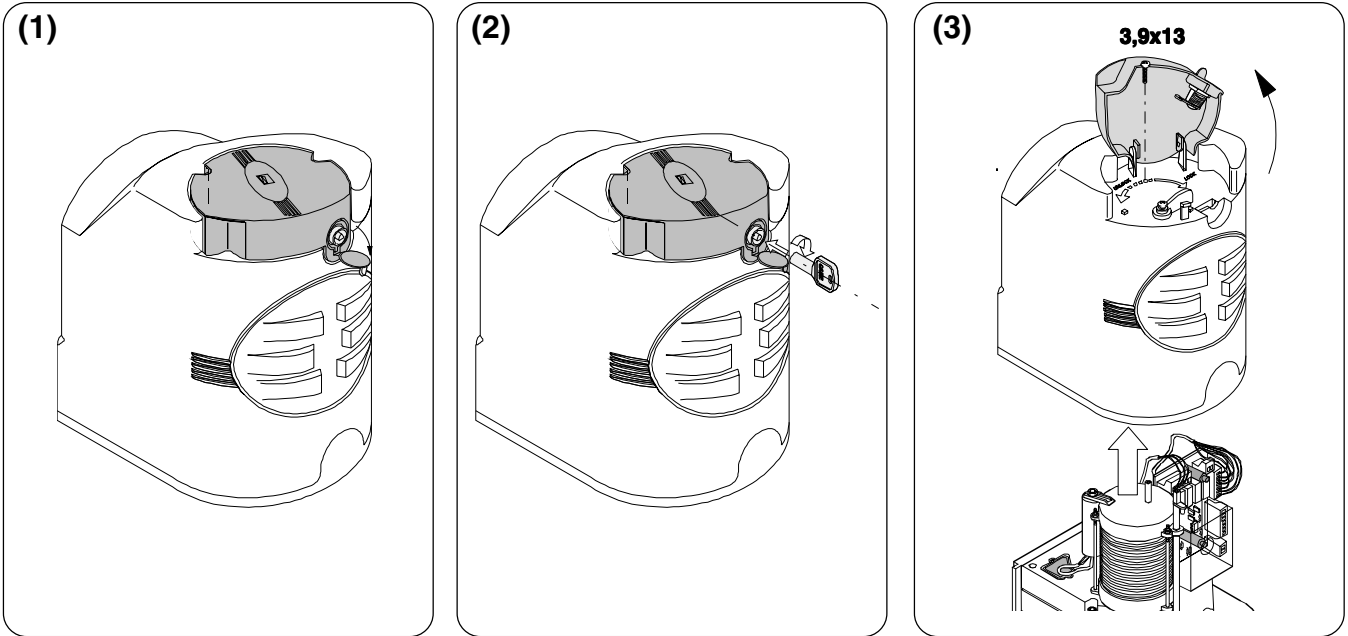

Open the lock cover cap (1). Push the key in and turn clockwise (2). Raise the cover, loosen the 3.9x13 screw and remove the cover from the gearmotor unit (3).

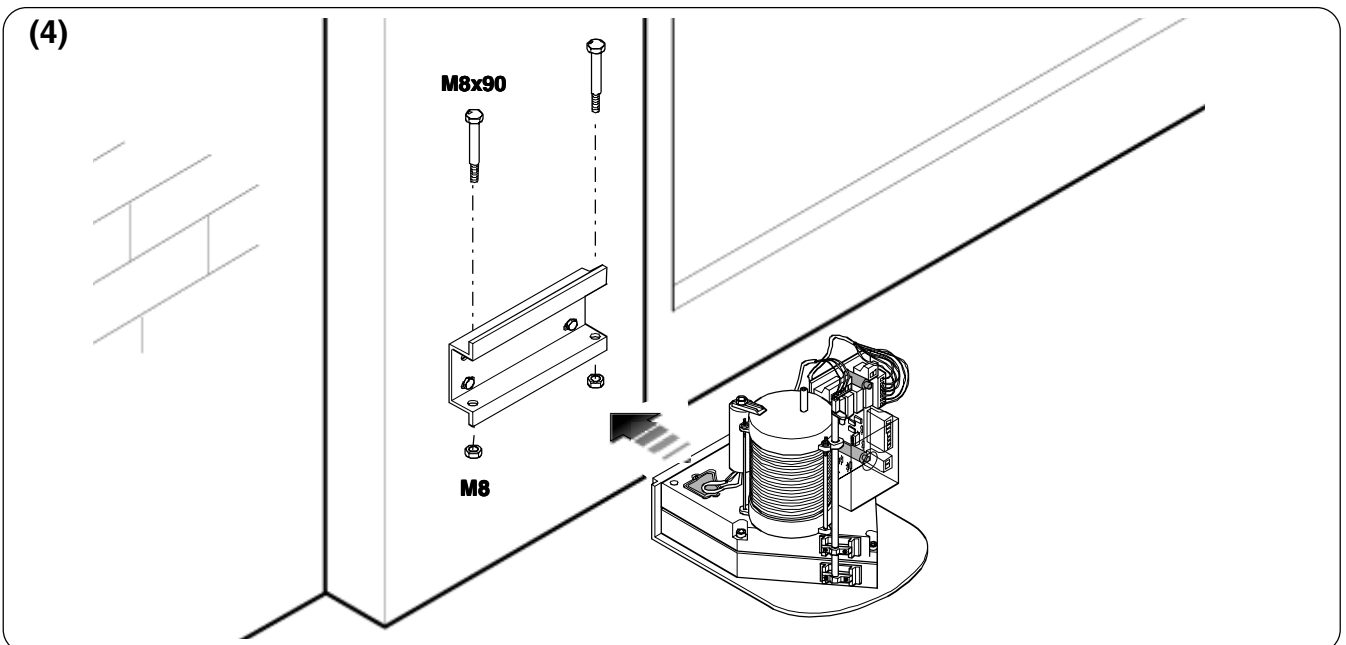

Insert the gearmotor in the base plate, align with the 4 holes and secure it with the two M8x90 bolts and nuts provided.

3.2 - Installing drive arms

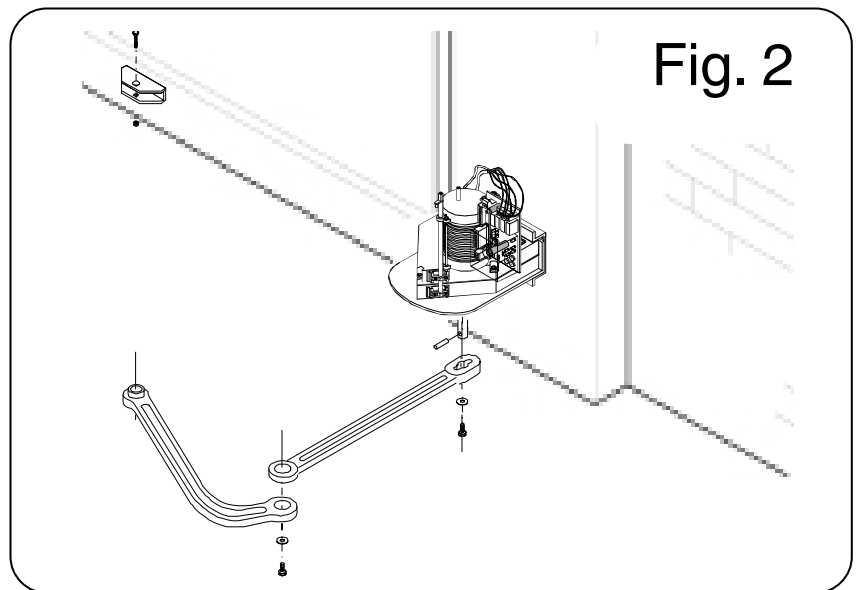
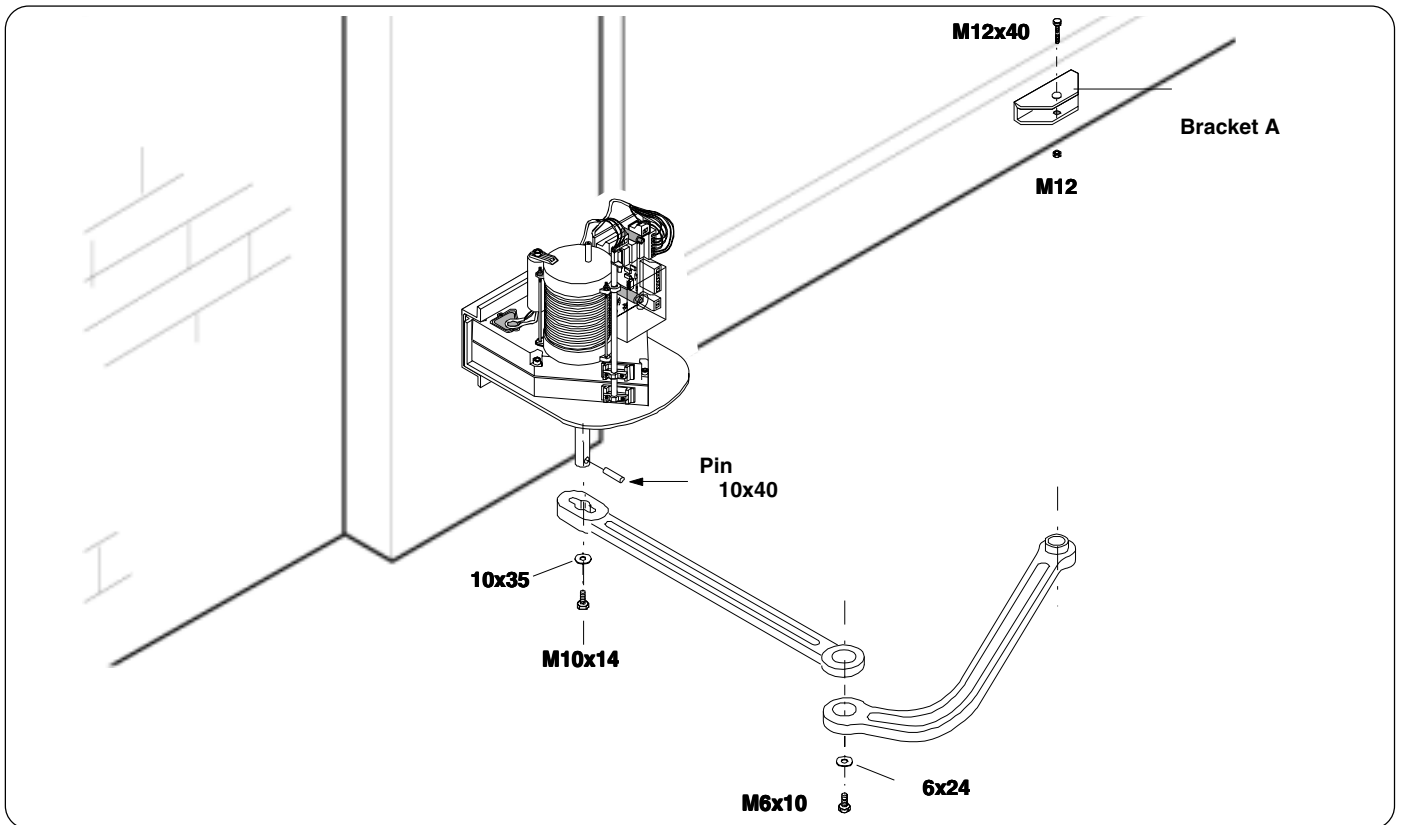

Insert the $\text{Ø}10\text{x}14$ pin and the straight arm into the shaft of the gearmotor and secure it with the M10x14 screw and 10x35 washer. Lubricate the pin of the straight arm. Join and secure the two arms with the M6x10 screw and 6x24 washer. Release the gearmotor and fix the curved arm to the bracket "A" with the M12x40 screw and the M12 nut, checking it is free moving. For application on the right-hand side see fig.2.

3.3 - Adjusting the open and shut cams

Adjustments of the microswitches with gearmotor installed on the right-hand side (internal view).

In closing: unblock the gearmotor (1) and allow the gate to reach the closing position desired (2). Turn the lower cam clockwise until the microswitch is inserted and lock it with the central screw (3).

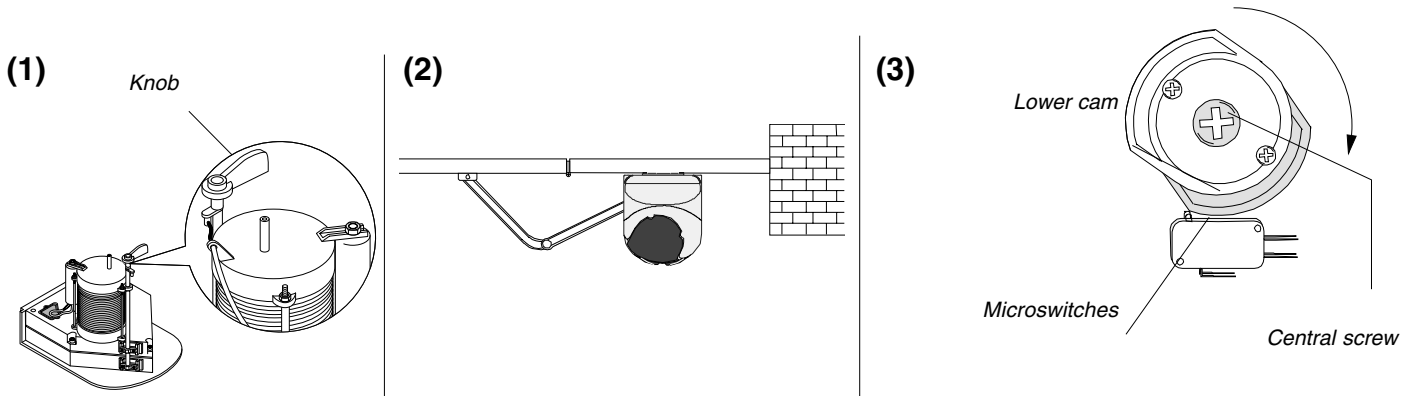

In opening: allow the gate to reach the open position desired (4). Turn the upper cam anticlockwise until the microswitch is inserted and lock it with the two upper screws (5).

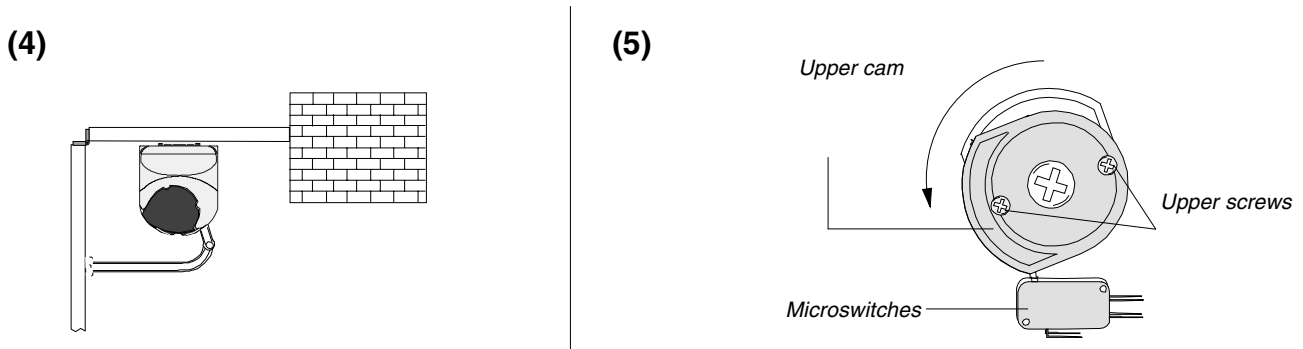

Adjustments of the microswitches with gearmotor installed on the left-hand side (internal view).

In opening: release the gearmotor (1) and allow the gate to reach the opening position desired (2). Turn the lower cam clockwise until the microswitch is inserted and lock it with the central screw (3).

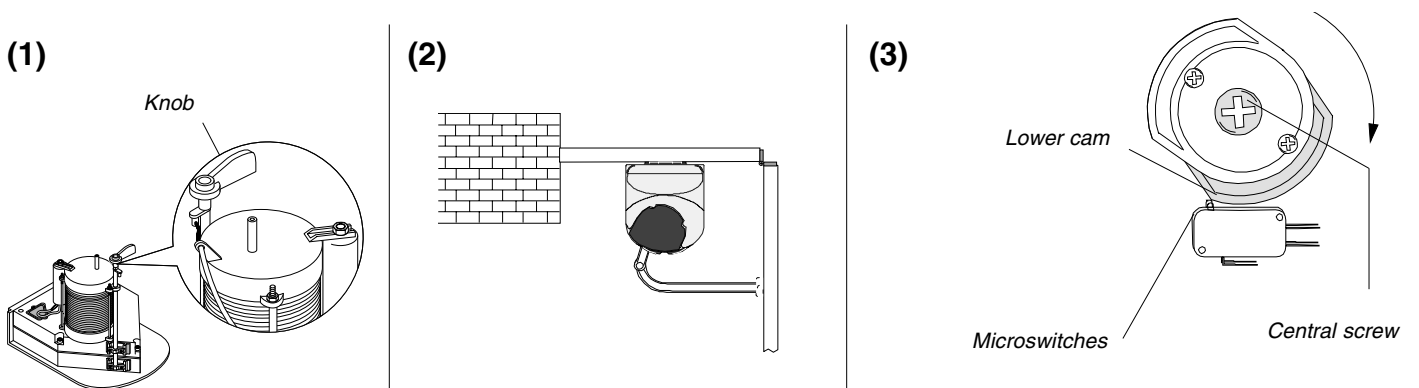

In closing: allow the gate to reach the closing position desired (4). Turn the upper cam anticlockwise until the microswitch is inserted and lock it with the two upper screws (5).

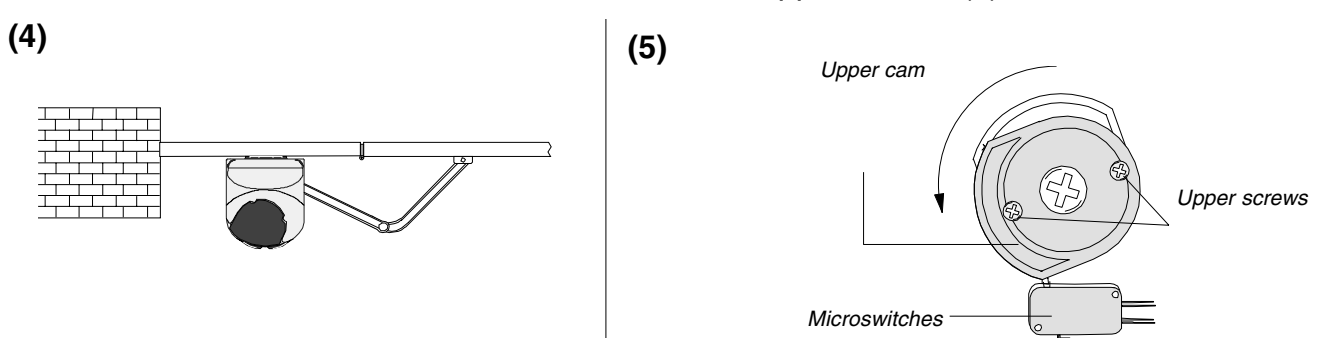

END OF INSTALLATION STAGE 3

**BEFORE STARTING STAGE 3 - Wiring
PLEASE CHECK THAT YOU HAVE CORRECTLY:**

	Ref	Page
1. Installed the Motors	3.1	8
2. Installed the Drive Arms	3.2	9
3. Adjusted the Open and Shut Cams	3.3	10

**NOW STAGE 3 IS FULLY COMPLETED YOU ARE READY TO BEGIN
STAGE 4 OF YOUR FAST AUTOMATION KIT INSTALLATION.**

STAGE 4

WIRING THE MOTORS

4.1 - Electrical connections to the ZF1 board with pair of gates

Fig.1

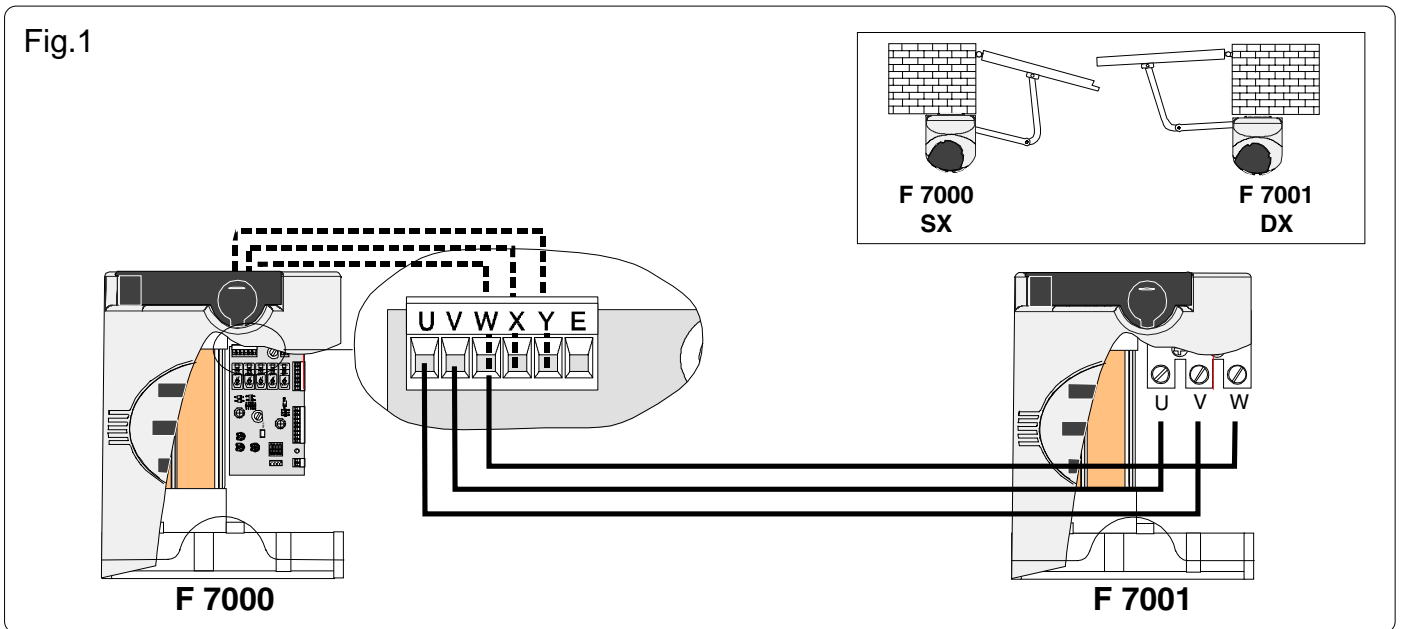

For gates with a delayed-closure left-hand gate, prepare the connection as shown in figure 1.

For gates with a delayed-closure right-hand gate, prepare the connection as shown in figure 2.
NB: always mount the F7000 gearmotor on the left pillar (internal view).

Fig. 2

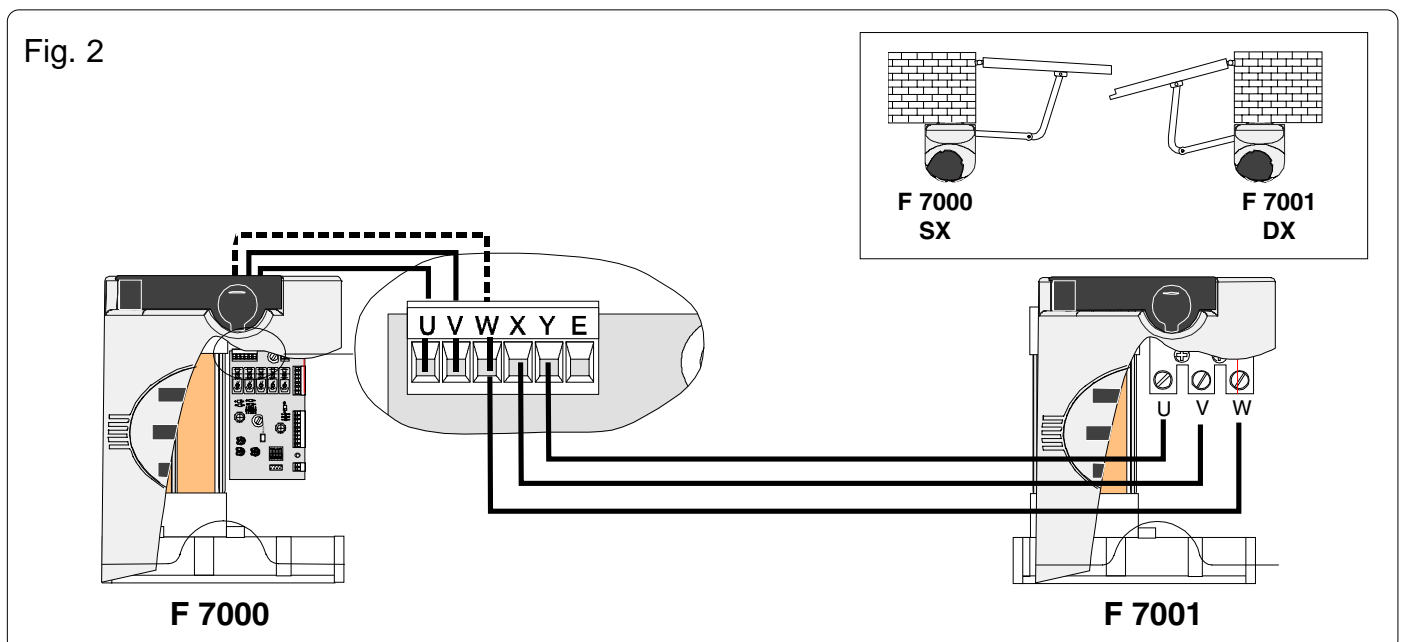

4.2 - Electrical connections to the ZF1 board with single gate

The gearmotor is prepared for gates with a left-hand gate (figure 1).

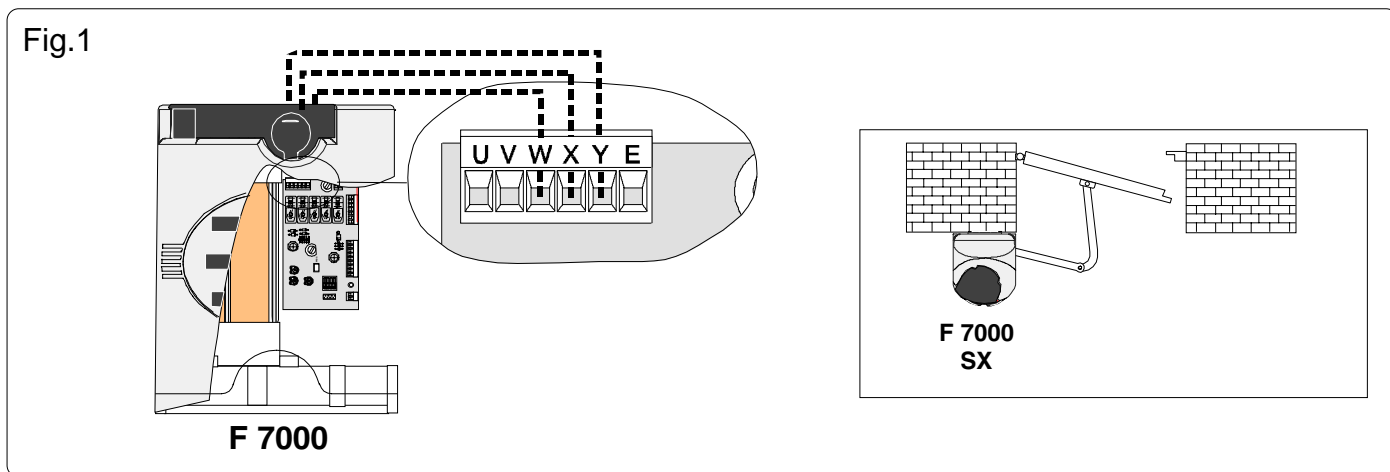

For gates with a right-hand gate, prepare the connection as shown in figure 2.

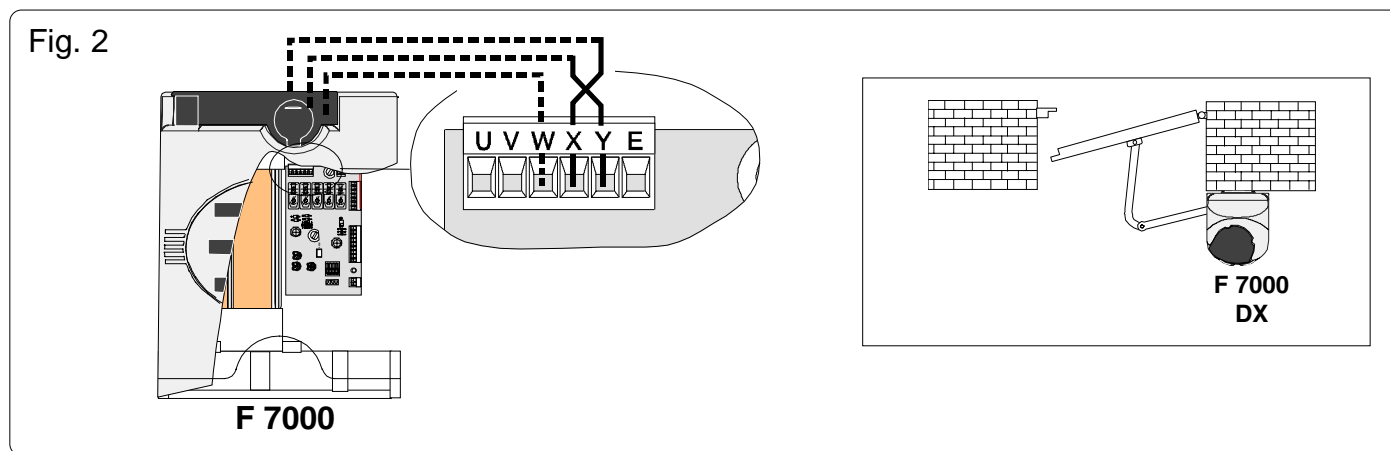

4.3 - Electrical Connections

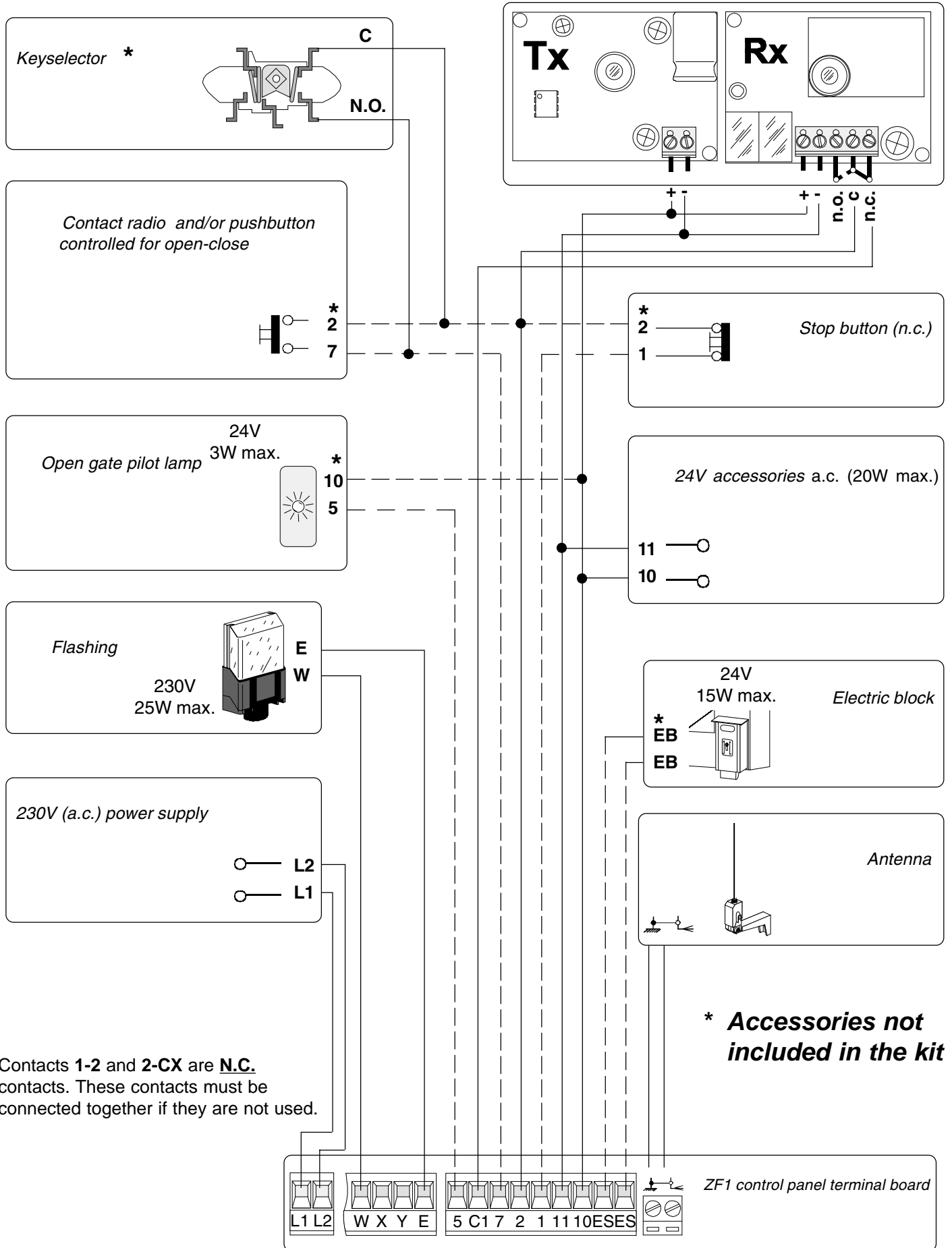

END OF INSTALLATION STAGE 4

BEFORE STARTING STAGE 5 - Commissioning the Control Panel
PLEASE CHECK THAT YOU HAVE CORRECTLY:

	Ref	Page
1. Wired the Motors	4.1	12
	4.2	13
2. Made the electrical connections	4.3	14

**NOW STAGE 3 IS FULLY COMPLETED YOU ARE READY TO BEGIN
STAGE 4 OF YOUR FAST AUTOMATION KIT INSTALLATION.**

STAGE 5

COMMISSIONING THE CONTROL PANEL

5.1 - Initial Wiring & Control Panel Set-Up

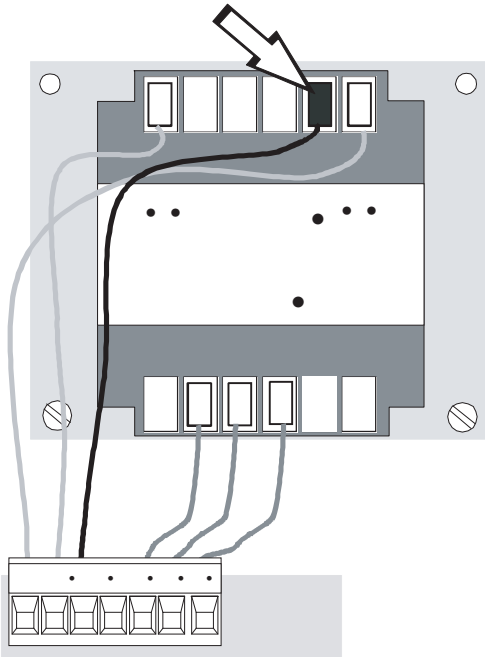

1. Connect power terminals L1 - L2 and a suitable earth (**L2 being LIVE!**)
2. Select the motor power setting on the transformer to level 1 for commissioning.

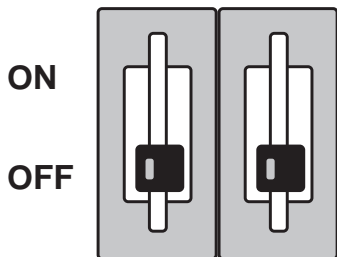

3. Select dipswitches 1 & 2 off for commissioning.
4. Ensure hard wire link is fitted between terminals 1 & 2 and 2 & C1.

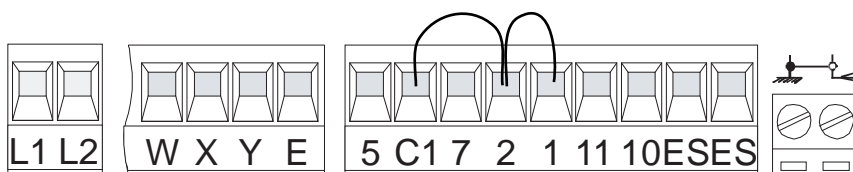

5.2 - Opening & Closing the Gates

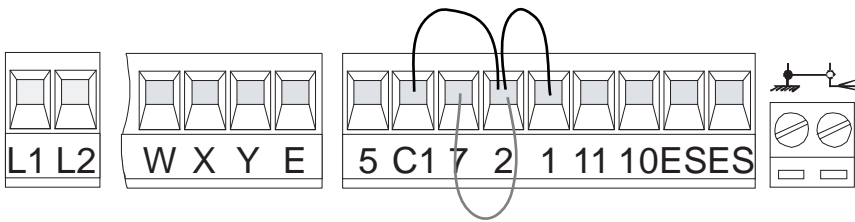

1. Momentarily pulse terminals 2 & 7 with a piece of wire trailing from terminal 2 and momentarily touching terminal 7.

The gates should start to open. If they start to close turn the power off to the control panel and change around either U-V (motor 1) or X-Y (motor 2) to change the motor direction.

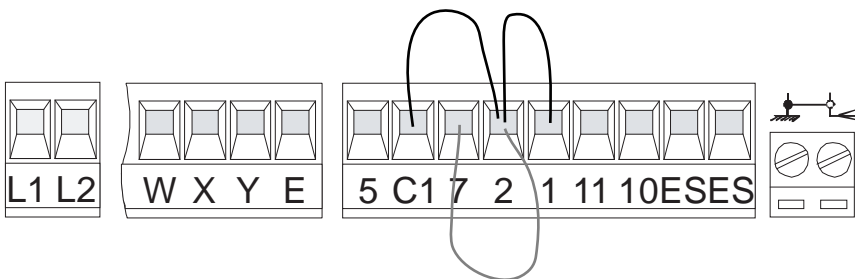

2. Once you have proven the motor direction use terminals 2 & 7 to open and close the gates with a trailing wire once again into terminal 2, momentarily touching terminal 7.

5.3 - Control Panel Adjustments

1. To delay one gate leaf, adjust potentiometer TR2M to delay the closing of gate no. 2 in the closing cycle.



2. To set the total running time of the motors, adjust potentiometer TL to allow the motors to run for a further 5-7 seconds after the movement cycle has been completed (i.e. fully open or fully closed).



3. Check the sensitivity of the gates by trying to physically stop the gate and adjust the power settings on the transformer accordingly. If more power is needed for heavier gates then switch off power and move transformer wire up to setting 2. For rechecking sensitivity, repeat process up to 3 or 4 if even more power is needed.

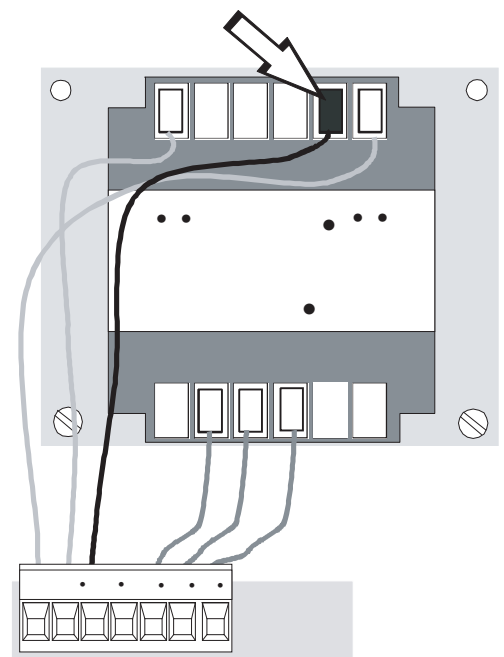

5.4 - Automatic Close & Activating Safety Photocells

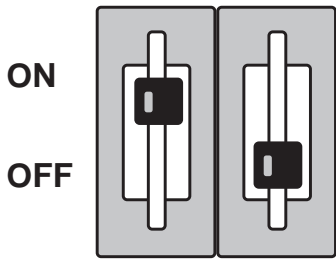

1. To select automatic closing, select dipswitch 1 **ON**.

Set the automatic closing time by adjusting potentiometer TCA.

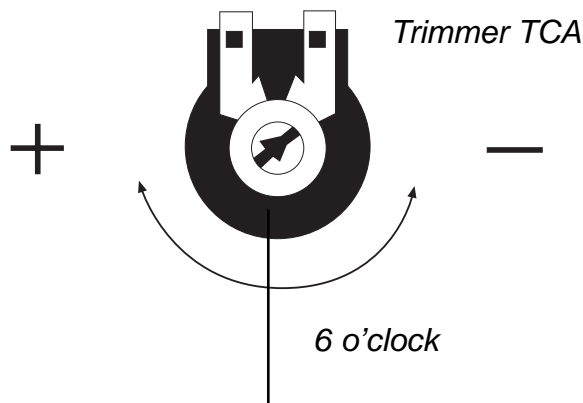

Fully anti-clockwise will automatically close the gates after approximately 10 seconds and fully clockwise will close the gates after approximately 80 seconds. A sensible setting is about halfway (i.e. 6 o'clock position) which will automatically close the gates after approximately 30 seconds.

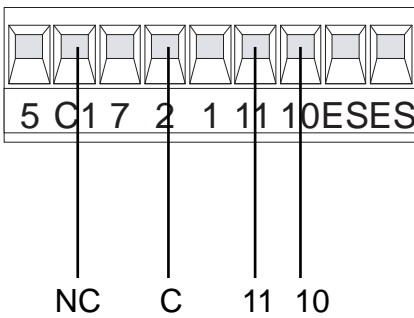

2. For re-opening during closing. Remove hard wire link between 2 & C1 and insert safety beam wires as shown.

5.5 - Programming the Remote Controls to the Control Panel

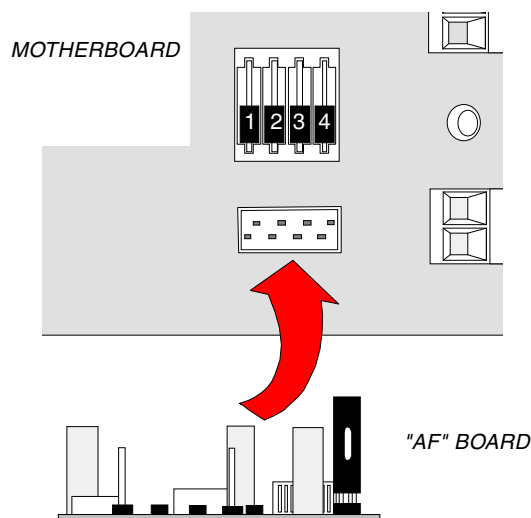

To use the remote control system, proceed as follows:

- A) Turn power OFF and insert AF radio frequency board then turn power back on.
- B) Code the transmitter. See the relevant instruction sheet (see 5.6).
- C) To store the code on the circuit board, proceed as follows:

Press and hold down the radio control save button on the radio receiver card (the signal LED will start to flash).

At the same time transmit on one of the buttons of your remote control; keep both the top button and the radio code save button pressed until the LED stops flashing and remains on constant. It will then go out to indicate that the code has been successfully stored.

NB If you wish to change the code on your transmitter in the future, simply repeat the procedure above with all the remotes on the installation.

WARNING: Disconnect the power supply from the control board before inserting OR removing the AF radio-frequency card from the socket.

5.6 - Coding the Additional Remote

Use on existing system

(with TOP at 433.92 MHz)

1. Press the key to encode until, after 7 seconds of flashing, the red signalling LED remains on. (fig A)
2. Within 10 seconds, bring the existing transmitter closer from the rear part and press the pushbutton you want to copy for a few seconds. (fig B)
Once it has been saved, the LED will flash 3 times and the transmitter will be ready for use.

Repeat 1 and 2 for the other pushbuttons. (NB: the code of another system can be saved).

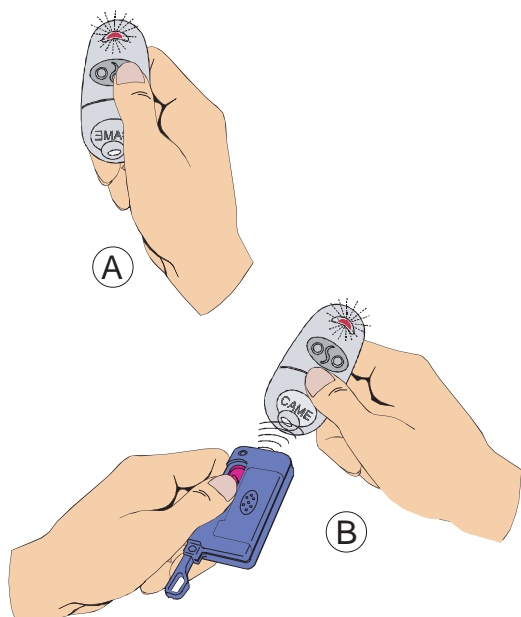

Use on new system

Consult the documentation of the electric board to save the first transmitter, then follow the procedure described above to duplicate it in the quantity desired.

Red signalling LED

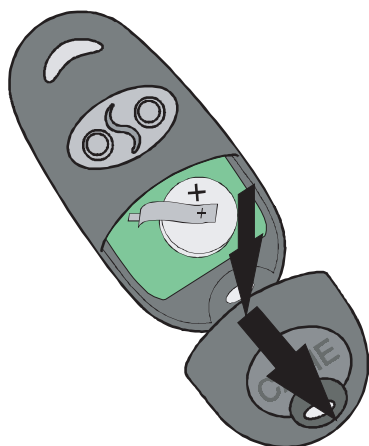

To open battery compartment, press and slide.

5.7 - Final Assembly

After completing the assembly operations, electrical connections and adjustments, insert the lid and secure it with the 3.9x13 screw. insert the release knob in "LOCK" position and secure it.

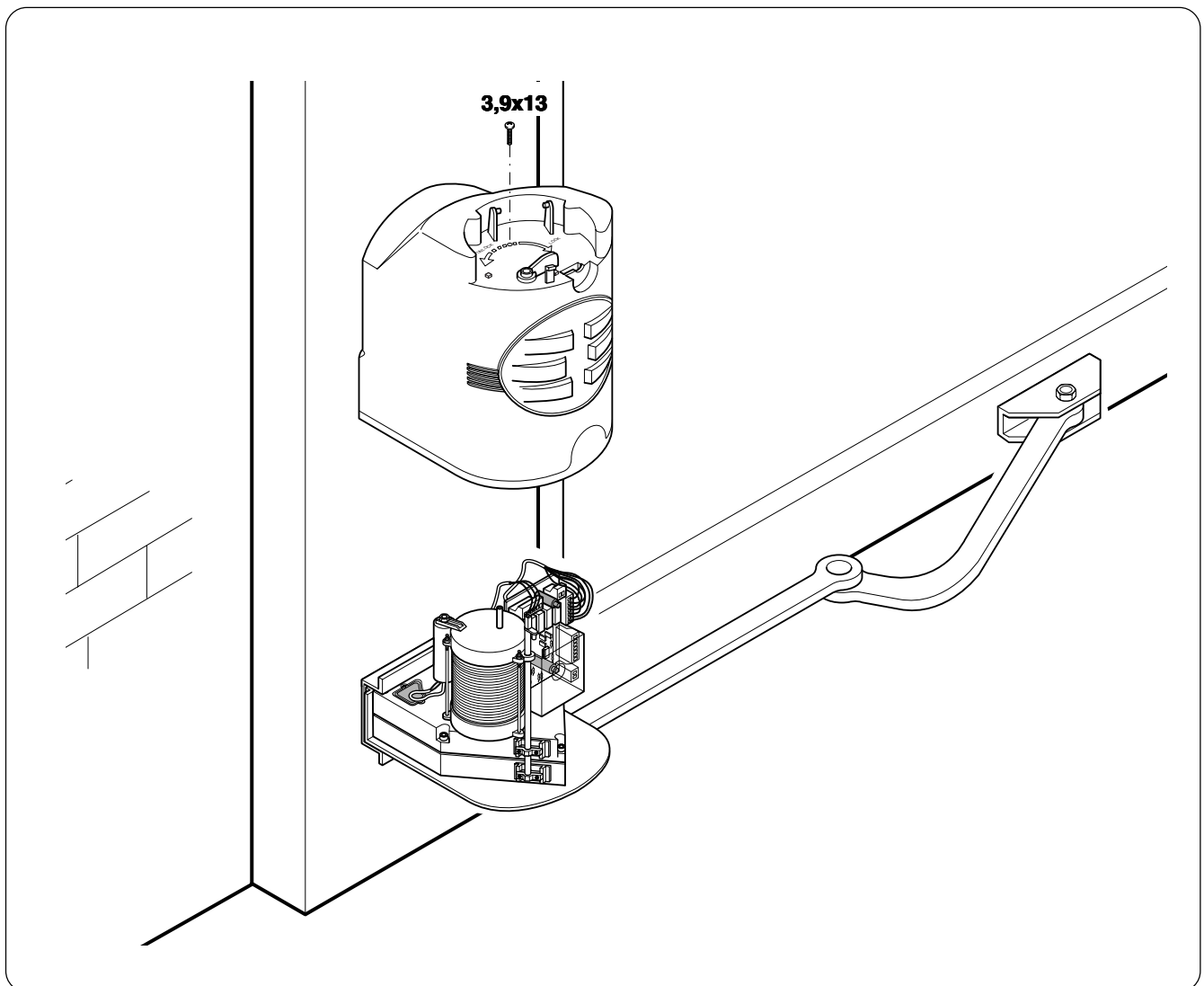

END OF INSTALLATION STAGE 5

PLEASE CHECK THAT YOU HAVE CORRECTLY:

	Ref	Page
1. Set power setting, set dipswitches for commissioning, ensure wire link is fitted between terminals 1 & 2 and 2 & C1	5.1	16
2. Set the opening and closing times for gates	5.2	17
3. Adjusted the control panel	5.3	18
4. If required, activated automatic closing and safety photocells	5.4	19
5. Programmed the remote to the control panel	5.5	20
6. Coded the remote controls	5.6	21
7. Fitted motor covers	5.7	22

NOW STAGE 3 IS FULLY COMPLETED YOU ARE READY TO BEGIN STAGE 4 OF YOUR FAST AUTOMATION KIT INSTALLATION.

STAGE 6

TECHNICAL INFORMATION

6.1 - Electrical Connections

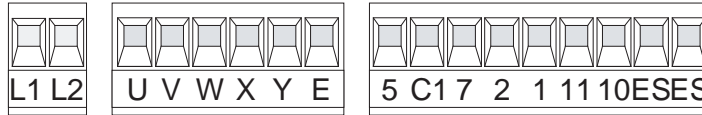

230V (a.c.) power input



Motor 1 single-phase 230V (a.c.) delayed opening

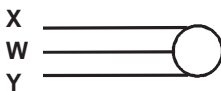

Motor 2 single-phase 230V (a.c.) delayed closure

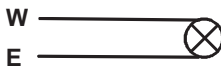

230V (a.c.) output in motion (e.g. flashing light - max. 25W)



(24V-3W max.) "gate-opened" signal lamp



(N.O.) contact radio and/or button for control (see dip 2)

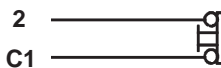

Contact (N.C.) for re-opening during the closing

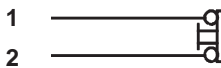

Pushbutton stop (N.C.)

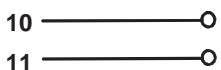

24V (a.c.) Powering accessories max. 20W

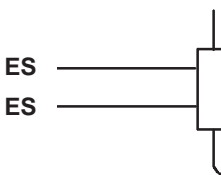

(12V-15W max.) connection for electrically-actuated lock

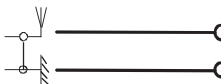

Antenna connection

6.2 - Function Selections

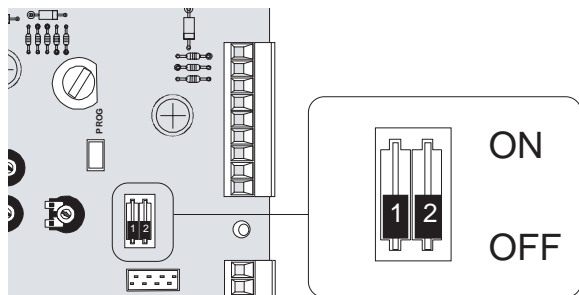

- 1 ON** Automatic closing **enabled**.
- 1 OFF** Automatic closing **disabled**.
- 2 ON** 'Open-stop-close-stop' function with button (2-7) and radio control (AF board inserted) **enabled**.
- 2 OFF** 'Open-close' function with button (2-7) and radio control (AF board inserted) **enabled**.

6.3 - Technical Description - ZF1 Control Panel

Description

The ZF1 control board is suitable for controlling 230V single-phase automated gates with power up to 320W, for FAST series ratiomotors (residential swing gates).

The board must be powered at 230V (a.c.) on the L1 and L2 terminals, and the inlet is protected with a 5A fuse, while the low voltage (24V) accessories are protected with a 3.15A fuse.

The accessory's total capacity (24V) should not exceed 20W.

Safety

Photocells can be connected to obtain:

- Re-opening during closure (2-C1), if the photocells identify an obstacle while the gate is closing, they will reverse the direction of movement until the gate is completely open;
- Total stop (1-2), shutdown of gate movement without automatic closing, a pushbutton radio remote control must be actuated to resume movement.

Optional accessories

- 12V Electric lock (ES-ES);
- Open gate pilot lamp (3W max.). Lamp that signals the gate is open, turns off when the time fixed for the gate's closing has elapsed (10-5).

Other functions

- Automatic closing. The automatic closing timer is automatically activated at the end of the opening cycle. The preset, adjustable automatic closing time is automatically interrupted by the activation of any safety system, and is deactivated after a STOP command or in case of power failure;
- "Operator present". Gate operates only when the pushbutton is held down (the radio remote control system is deactivated). It is activated when the T.L. trimmer is set to the minimum.

Adjustments

- Automatic closure time;
- Delay in closing of the M2 motor;
- Operating time.

6.4 - Motherboard

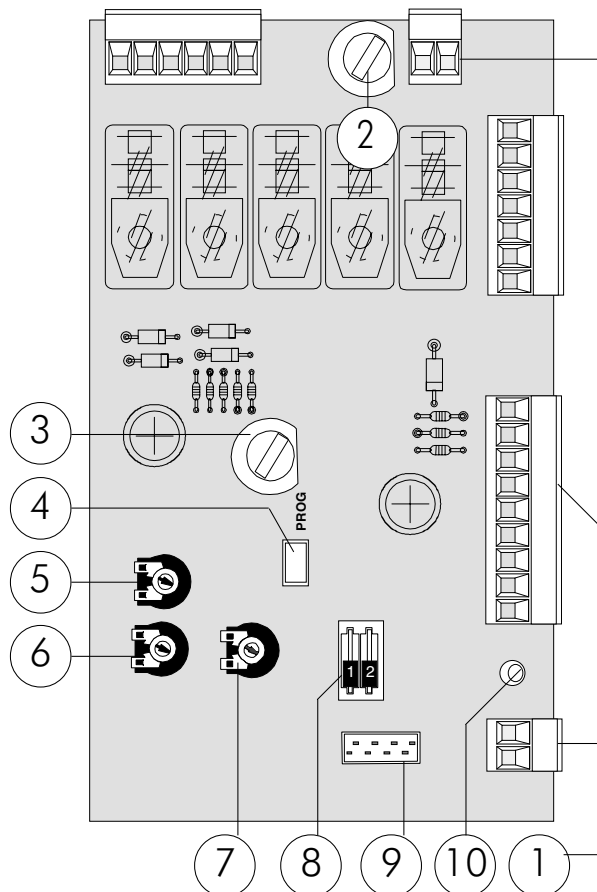

Main Components

- 1 Terminal block for external connections
- 2 Line fuse, 5A
- 3 Fuse on accessory power line, 3.15A
- 4 Radio-code save button
- 5 Trimmer for adjustment delay on closing cycle - motor 2
- 6 Trimmer for adjustment operating time
- 7 Trimmer for adjustment automatic closing
- 8 2-dip function switch
- 9 Socket AF radio frequency board
- 10 Signal LED

6.5 - Adjustments

Trimmer T.R.2M. = Adjustment delay during closure of 2nd motor, min 1" max 10".

Trimmer T.L. = Adjusts operating time, min 15" max 120".

(**Note:** the "operator present" function is activated by setting the operating time to the minimum.)

Trimmer T.C.A. = Adjusts automatic closing time, min 0" max 120".

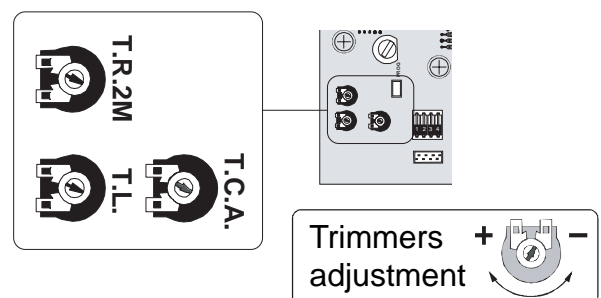

7. TROUBLESHOOTING GUIDE

A MULTIMETER WILL BE NEEDED

PROBLEM	SOLUTION
GATE WILL NOT RESPOND WHEN GIVEN A COMMAND	<ol style="list-style-type: none"> 1. CHECK POWER SUPPLY TO THE CONTROL PANEL. 2. CHECK CONTROL PANEL FUSES. 3. CHECK HARD WIRE LINK FITTED BETWEEN TERMINALS 1 & 2.
GATES ARE OPEN BUT WILL NOT CLOSE AND GREEN LED IS FLASHING	<ol style="list-style-type: none"> 1. CHECK SAFETY BEAMS ARE WIRED CORRECTLY. (IF MORE THAN ONE SET OF BEAMS ARE FITTED THEY MUST BE WIRED IN SERIES.) 2. CHECK THAT THERE IS POWER GOING TO THE BEAMS, IF NOT RESTORE POWER. 3. IF SAFETY BEAMS ARE NOT FITTED ENSURE THAT A HARD WIRE LINK IS FITTED BETWEEN TERMINALS 2 & C1 4. REMOVE SAFETY BEAM WIRES 2 & C1 FROM CONTROL PANEL AND CHECK IF YOU HAVE A NORMALLY CLOSED CIRCUIT COMING FROM THE BEAMS.
WHEN COMMISSIONING GATE AUTOMATICALLY OPENS BUT DOES NOT AUTOMATICALLY CLOSE	<ol style="list-style-type: none"> 1. MOTOR WIRES ARE WRONG WAY ROUND. CHECK THE WIRING DIAGRAM FOR CORRECT DIRECTION.

PROBLEM	SOLUTION
GATES WILL NOT RESPOND TO REMOTE CONTROL COMMAND	<ol style="list-style-type: none"> 1. AF FREQUENCY CARD NOT FITTED TO CONTROL PANEL. 2. REMOTE CONTROL HAS NOT BEEN PROGRAMMED INTO THE CONTROL PANEL. 3. REMOTE CONTROL HAS THE WRONG CODE SETTING. 4. WRONG FREQUENCY CARD FITTED FOR THE REMOTE CONTROL. 5. TERMINALS 1 AND 2 ARE NOT LINKED.

IF THE PROBLEM IS STILL APPARENT CONTACT THE
CAME TECHNICAL HELPLINE:

0115 921 0430

THIS INSTALLATION WAS COMPLETED BY:	
.....	
NAME.....	
ADDRESS.....	
.....	
.....	
.....	
TEL.....	MOBILE.....
DATE OF INSTALLATION.....	

NOTES

NOTES

CONTACT INFORMATION

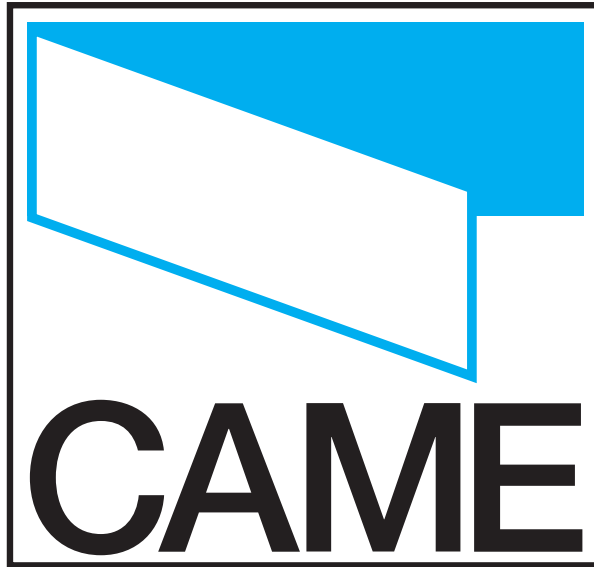

CAME UNITED KINGDOM LTD

UNIT 3

ORCHARD PARK INDUSTRIAL ESTATE
TOWN STREET, SANDIACRE, NOTTINGHAM NG10 5BP

TEL: **0115 921 0430**

FAX: **0115 921 0431**

INTERNET : **www.cameuk.com**

E-MAIL: **enquiries@cameuk.com**

THIS INSTALLATION WAS COMPLETED BY:

.....

NAME.....

ADDRESS.....

.....

.....

.....

TEL..... MOBILE.....

DATE OF INSTALLATION.....